

3MT28A_1.5 Series

3W - Single Output DC-DC Converter - Fixed Input - Isolated & Unregulated

DC-DC Converter

3 Watt

- ⊕ Miniature SMD package
- ⊕ Operating temperature range: -40°C to +85°C
- ⊕ 1.5KVDC isolation
- ⊕ Low temperature rise
- ⊕ Internal SMD construction
- ⊕ Industry standard pinout
- ⊕ Short circuit protection (SCP)

The 3T14W_1.5 Series is designed for application where isolated output is required from a distributed power system.

These products apply to:

- 1) Input voltage range $\pm 10\%$ Vin;
- 2) 1.5KVDC input and output isolation;
- 3) Regulated and low ripple noise is not required.

Such as: digital circuits and low frequency analog circuits and relay drive circuit.



Common specifications	
Short circuit protection:	Continuous, automatic recovery
Temperature rise at full load:	25°C TYP
Cooling:	Free air convection
Operation temperature range:	-40°C~+85°C Power derating above 71°C
Storage temperature range:	-55°C ~+125°C
Lead temperature range:	300°C MAX, 1.5mm from case for 10 sec
Storage humidity range:	< 95%
Case material:	Epoxy Resin [UL94-V0]
MTBF (MIL-HDBK-217F@25°C):	>3,500,000 hours
Weight:	2.0g

Output specifications					
Item	Test condition	Min	Typ	Max	Units
Line regulation	For Vin change of $\pm 1\%$			± 1.2	%
Load regulation	10% to 100% load		10	15	%
Output voltage accuracy	See tolerance envelope curve				
Temperature coefficient	100% load			± 0.03	%/°C
Ripple & Noise*	20MHz Bandwidth		100		mVp-p
Switching frequency	100% Full load, nominal input		100	300	KHz

* Ripple and noise tested with „parallel cable“ method. See detailed operation instructions at DC-DC application notes.

Isolation specifications					
Item	Test condition	Min	Typ	Max	Units
Isolation voltage	Tested for 1 minute, leakage current less than 1 mA	1500			VDC
Isolation resistance	Test at 500VDC	1000			MΩ
Isolation capacitance	Input/Output, 100KHz/1V		17		pF

Input specifications					
Item	Test condition	Min	Typ	Max	Units
Input filter	Capacitor				
Input surge voltage (1 sec. max.)		-0.7		9	VDC

EMC specifications		
EMI	CE	CISPR22/EN55022 CLASS B (External Circuit Refer to EMC recommended circuit)
EMS	ESD	IEC/EN61000-4-2 Contact ± 8 KV perf. Criteria B

Model selection:

WCTP**_xxyyN##O

W= Watt; C= Case; T= Type; P= Pinning; **= Voltage Variation (omitted $\pm 10\%$); xx= Vin; yy= Vout; N= Numbers of Output; ##= Isolation (kVDC); O= output regulation

Example:

3MT28A_0505S1.5UP

3= 3Watt; MT28= Micro SMT28; A= Pinning; 5Vin; 5Vout; S= Single Output; 1.5= 1.5kVDC; U= Unregulated output; P= Short Circuit Protection

Note:

1. Operation under minimum load will not damage the converter; However, they may not meet all specifications.
2. Max. Capacitive Load is tested at nominal input voltage and full load.
3. Unless otherwise noted, All specifications are measured at Ta=25°C, humidity<75%, nominal input voltage and rated output load.
4. In this datasheet, all test methods are based on our corporate standards.
5. All characteristics are for listed models, and non-standard models may perform differently. Please contact our technical support for more detail.
6. Please contact our technical support for any specific requirement.
7. Specifications of this product are subject to changes without prior notice.

Part Number	Input Voltage [VDC]		Output Voltage [VDC]	Output Current [mA]		Capacitive load [μ F, max.]	Input Current [mA]		Reflected ripple current [mA, Typ.]	Efficiency [%, Typ.]
	Nominal	Range		Max	Min		Max	Min		
3MT28A_0505S1.5UP	5	4.5-5.5	5	600	60	220	709	30	25	85

3MT28A_1.5 Series

3W - Single Output DC-DC Converter - Fixed Input - Isolated & Unregulated

EMC recommended circuit

EMI Typical Recommended Circuit

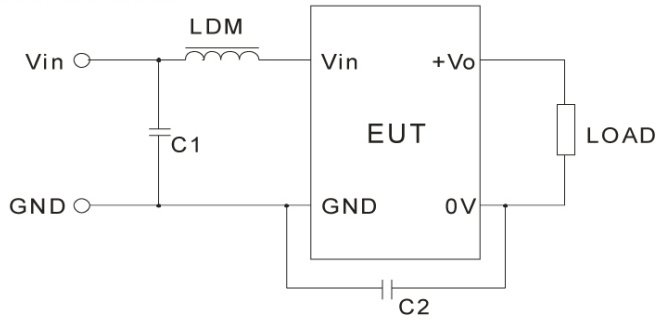

Recommended typical circuit parameters:

Model	Vin: 5V
C1	4.7 μ F /50V
C2	470pF/2KV
LDM	6.8 μ H

Typical characteristics

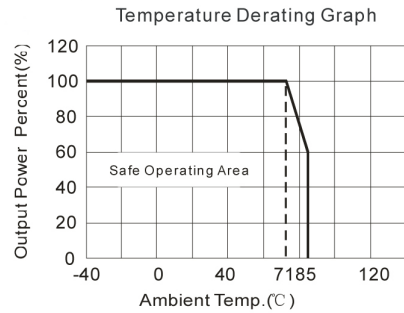
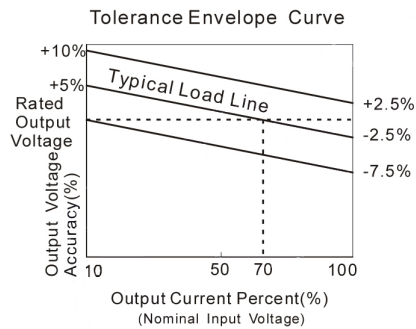

Efficiency VS Input Voltage curve (Full Load)

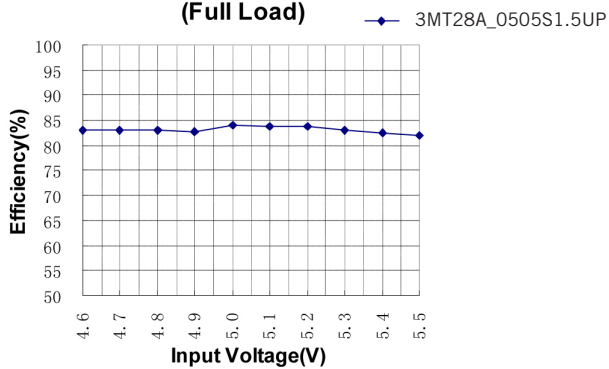

Efficiency VS Output Load curve (Vin=Vin-nominal)

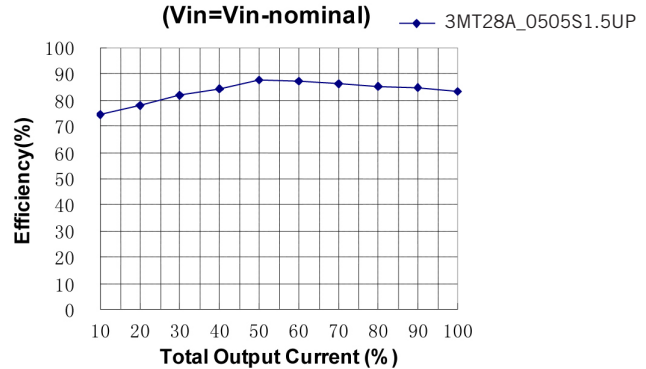

3MT28A_1.5 Series

3W - Single Output DC-DC Converter - Fixed Input - Isolated & Unregulated

Mechanical dimensions Recommended footprint

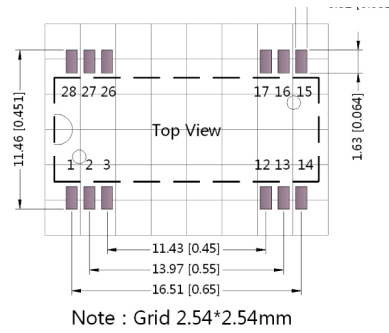
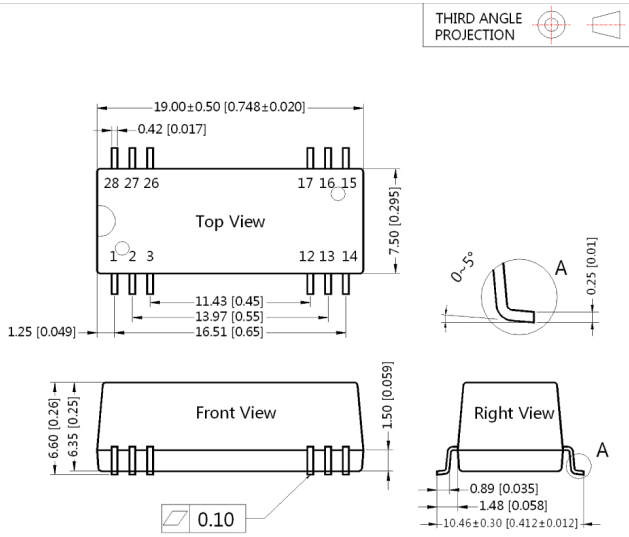

PIN CONNECTION	
Pin	Function
1	Vin
2	GND
3	GND
12	0V
13	Vo
14, 15, 16, 17	NC
26, 27, 28	NC

NC:No Connection

Note:
 Unit: mm[inch]
 Pin section tolerances: ± 0.10mm[± 0.04inch]
 General tolerances: ± 0.25mm[± 0.010inch]

Tube outline dimensions

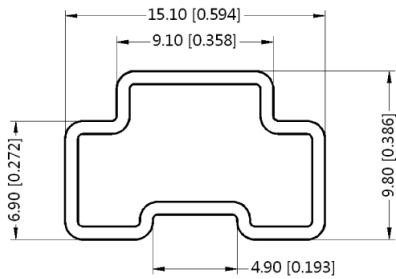

Note:
 Unit: mm[inch]
 General tolerances: ± 0.5mm[± 0.020inch]

L=530mm[20.866inch]
 Devices per tube quantity: 26pcs

L=220mm[8.661inch]
 Devices per tube quantity: 10pcs

Test configurations

Input Reflected-Ripple Current Test Setup

Input reflected-ripple current is measured with an inductor Lin and Capacitor Cin to simulate the source impedance.

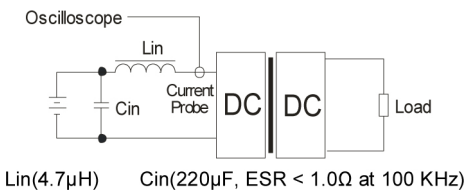

3MT28A_1.5 Series

3W - Single Output DC-DC Converter - Fixed Input - Isolated & Unregulated

Application note

1) Requirement on output load

To ensure this module operate efficiently and reliably, the minimum output load could not be less than 10% of the full load. If the actual output power is very small, please connect a resistor to the output in parallel to increase the load.

2) Recommended circuit

Recommended circuit

If you want to further decrease the input/output ripple, an capacitor filtering network may be connected to the input and output ends of the DC/DC converter, refer to Figure 1.



Figure 1

It should also be noted that the capacitance of the capacitor must be proper. If the capacitance is too large, a startup problem might arise. For ensuring every channel of output can provide a safe and reliable operation, the recommended capacitance of the capacitor refer to Table 1.

Vin (VDC)	Cin (μF)	Vo (VDC)	Cout (μF)
5	4.7	5	10

It's not recommended to connect any external capacitor in the application field with less than 0.5 watt output.

Table 1

3) Overload protection

Under normal operating conditions, the output circuit of these products have not overload protection. The simplest method is to add a breaker circuit in the circuit.

4) Output Voltage Regulation and Over-voltage Protection Circuit

The simplest device for output voltage regulation, over-voltage and over-current protection is a linear regulator with overheat protection which is connected to the input or output in series (Figure 4) and an capacitor filtering network. the recommended capacitance of the capacitor refer to Table 1, linear regulator based on the actual voltage and current to make a reasonable selection.

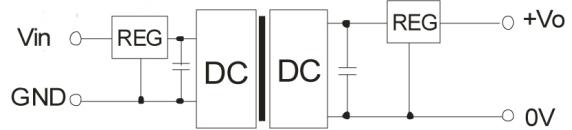

Figure 2

5) It is not recommended to increase the output power capability by connecting two or more converters in parallel. The product is not hot-swappable