



## 5S7BT\_D3 Series

5W - Dual Output - Wide Input - Isolated & Regulated  
IGBT dedicated DC-DC converter

### DC-DC Converter

5 Watt

- ⊕ Efficiency up to 80%
- ⊕ Temperature range: -40°C~+105°C
- ⊕ Dual Output Voltage
- ⊕ 3000VDC isolation voltage
- ⊕ Short circuit protection (SCP)
- ⊕ Ultra low isolation capacitance
- ⊕ Ultra Compact SIP package
- ⊕ Good temperature characteristic
- ⊕ RoHS Compliance
- ⊕ IGBT dedicated regulated DC-DC converter
- ⊕ No-load operation allowed

The 5S7BT\_D3 Series are DC-DC converters for IGBT drivers. Their ultra low isolation capacitance can improve the capability of anti-interference. The built-in common-ground mode of the unique asymmetric voltage output mode reduces the driver loss of IGBT driver. They feature short-circuit protection and auto-recovery, and can be widely used in:

- General inverter
- AC servo drive system
- Electric welding machine
- Uninterruptible power supply (UPS)



Common specifications	
Short circuit protection:	Continuous, automatic recovery
Temperature rise at full load:	30°C TYP, 40°C MAX (Ta=25°C)
Cooling:	Free air convection
Operation temperature range:	-40°C – +105°C
Storage temperature range:	-55°C – +125°C
Lead temperature	300°C MAX, 1.5mm from case for 10 sec
Storage humidity range:	< 95%
Case material:	Black flame-retardant and heat-resistant plastic [UL94-V0]
MTBF:	>3,500,000 hours
Weight:	4.3g

EMC specifications		
EMI	CE	CISPR22/EN55022 CLASS B (External Circuit Refer to EMC recommended circuit)
EMI	RE	CISPR22/EN55022 CLASS B (External Circuit Refer to EMC recommended circuit)
EMS	ESD	IEC/EN61000-4-2 Contact ±8KV perf. Criteria B

Input specifications					
Item	Test condition	Min	Typ	Max	Units
Input voltage	• 5S7BT_121508_D3P	-0.7		15	VDC
	• 5S7BT_121509_D3P	-0.7		13	VDC
	• 15VDC	-0.7		16	VDC
	• 24VDC	-0.7		26	VDC
Hot plug	Unavailable				
Input filter	Capacitor				

Isolation specifications					
Item	Test condition	Min	Typ	Max	Units
Isolation voltage	Input-Output, tested for 1 minute and leakage current less than 1mA	3000			VAC
Isolation resistance	Input-Output, test at 500VDC	1000			MΩ
Isolation capacitance	Input/Output, 100KHz/0.1V		6.6		pF

#### Model selection:

WCTP\*\*\_xxyyN##O

W= Watt; C= Case; T= Type; P= Pinning; \*\*= Voltage Variation (omitted ± 10%); xx= Vin; yy= Vout; N= Numbers of Output; ##= Isolation (kVDC); O= output regulation

#### Example:

5S7BT\_121509D3P

5 = 5 Watt; S7=SIP7; BT= IGBT Serie; 12=12Vin; 15= +15Vout; 09= -9Vout; D=Dual Output; 3= 3KVDC; P= Short Circuit Protection (SCP)

Part Number	Input Voltage (Range) [V]	Input current full load/ no load [mA, typ]	Output Voltage [VDC, +Vo/-Vo]	Output current [mA, +Vo/-Vo]	Max. capacitive load [μF]	Efficiency [%, typ]
5S7BT_121508_D3P	12 (9-15)	223/20	+12/-8.0	+100/-80	220	80
5S7BT_121509_D3P	12 (11.6-12.4)	162/20	+15/-8.7	+80/-40	220	80
5S7BT_151509_D3P	15 (14.5-15.5)	130/20	+15/-8.7	+80/-40	220	80
5S7BT_1509_D3P	15 (14.5-15.5)	84/20	+9/-	+111/-	220	80
5S7BT_150909_D3P	15 (14.5-15.5)	84/20	+9/-9	+55/-55	220	80
5S7BT_151709_D3P	15 (14.5-15.5)	143/20	+17/-8.7	+80/-40	220	80
5S7BT_241509_D3P	24 (23.3-24.7)	81/20	+15/-8.7	+80/-40	220	80

## 5S7BT\_D3 Series

5W - Dual Output - Wide Input - Isolated & Regulated  
IGBT dedicated DC-DC converter

Output specifications						
Item		Test condition	Min	Typ	Max	Units
Output voltage	• 5S7BT_121508_D3P	+Vo: Vin=12VDC, Pin6 & Pin7 +Io=+100mA	14	15	16	VDC
		-Vo: Vin=12VDC, Pin5 & Pin6 -Io=-80mA	-7	-8	-9	VDC
	• 5S7BT_121509_D3P	+Vo: Vin=12VDC, Pin6 & Pin7 +Io=+80mA	14	15	16	VDC
		-Vo: Vin=12VDC, Pin5 & Pin6 -Io=-40mA	-7	-8.7	-10	VDC
	• 5S7BT_151509_D3P	+Vo: Vin=15VDC, Pin6 & Pin7 +Io=+80mA	14	15	16	VDC
		-Vo: Vin=15VDC, Pin5 & Pin6 -Io=-40mA	-7	-8.7	-10	VDC
	• 5S7BT_1509_D3P	+Vo: Vin=15VDC, Pin6 & Pin7 +Io=+111mA	8	9	10	VDC
-Vo: -	-	-	-	-	VDC	
• 5S7BT_150909_D3P	+Vo: Vin=15VDC, Pin6 & Pin7 +Io=+55mA	8	9	10	VDC	
	-Vo: Vin=15VDC, Pin5 & Pin6 -Io=-55mA	-8	-9	-10	VDC	
• 5S7BT_151709_D3P	+Vo: Vin=15VDC, Pin6 & Pin7 +Io=+80mA	16.5	17	18	VDC	
	-Vo: Vin=15VDC, Pin5 & Pin6 -Io=-40mA	-7	-8.7	-10	VDC	
• 5S7BT_241509_D3P	+Vo: Vin=24VDC, Pin6 & Pin7 +Io=+80mA	14	15	16	VDC	
-Vo: Vin=24VDC, Pin5 & Pin6 -Io=-40mA	-7	-8.7	-10	VDC		
Output voltage accuracy	• 5S7BT_1509_D3P • Other models	See tolerance envelope curve		±4	±6	%
Line regulation		Input voltage range		±1.2	±1.5	%
Load regulation	• 5S7BT_1509_D3P • Other models	10% to 100% load		12	26	%
		10% to 100% load, positive output		8	15	%
		10% to 100% load, negative output		10	15	%
Temperature drift coefficient		100% load			±0.03	%/°C
Ripple & Noise*		20MHz Bandwidth		100	200	mVp-p
Switching frequency		Full load, nominal input		300		KHz

\*Test ripple and noise by "parallel cable" method. See detailed operation instructions at DC-DC application notes.

## Typical characteristics

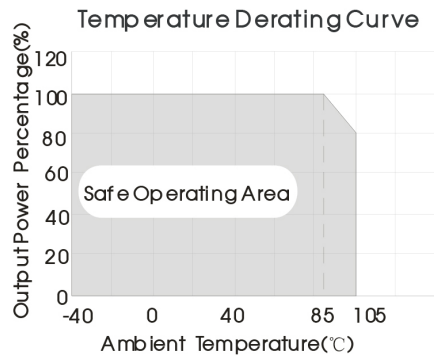
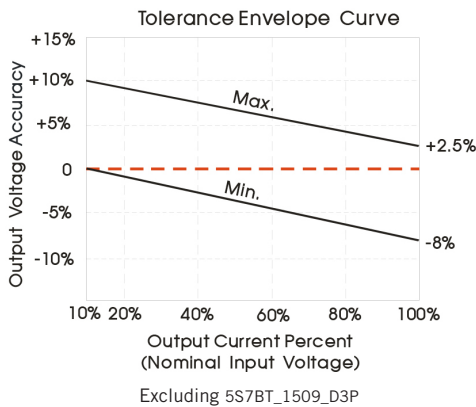

# 5S7BT\_D3 Series

5W - Dual Output - Wide Input - Isolated & Regulated  
IGBT dedicated DC-DC converter

## Efficiency

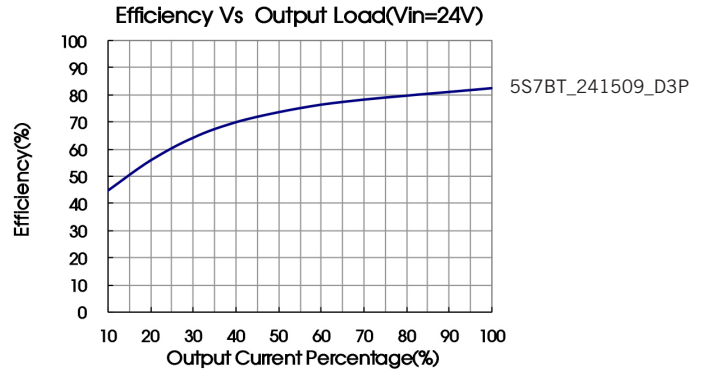
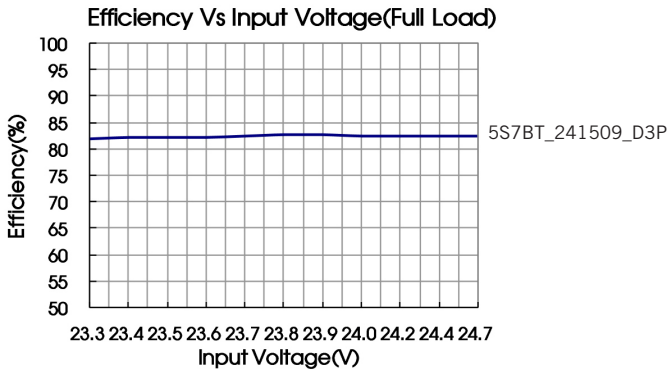
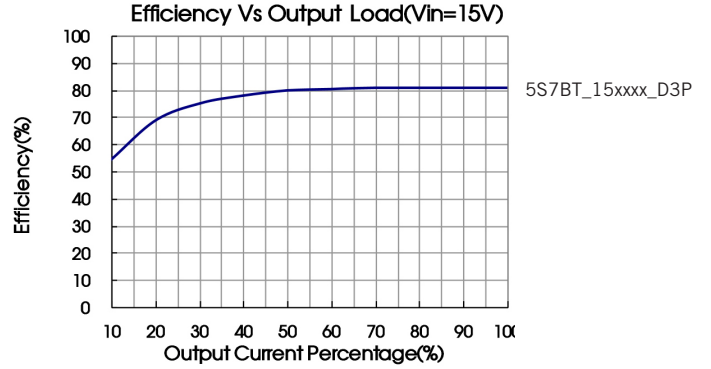
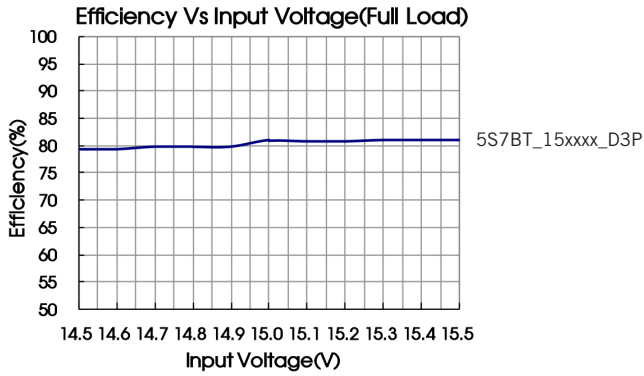

## Typical application

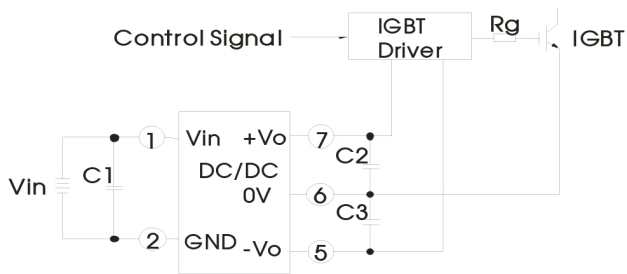

C1 / C2 / C3
100uF/35V (Low internal resistance capacitance)

Note: On both ends of capacitance C2 and C3 shunt respectively a capacitance value in 1uF - 10uF ceramic capacitors.

## EMC solution-recommended circuit

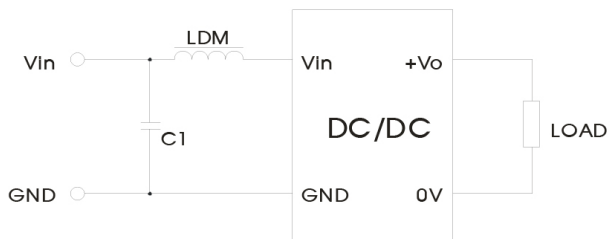

Input voltage (VDC)	12/15/24
EMI / C1	4.7µF/50V
EMI / LDM	12µH

It is not allowed to connect modules output in parallel to enlarge the power.

# 5S7BT\_D3 Series

5W - Dual Output - Wide Input - Isolated & Regulated  
IGBT dedicated DC-DC converter

## Mechanical dimensions

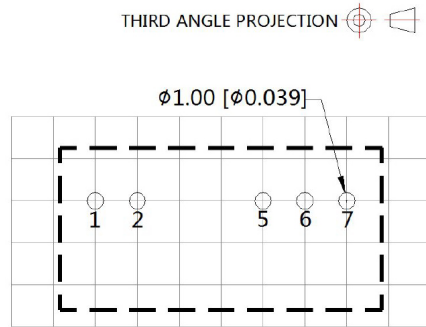
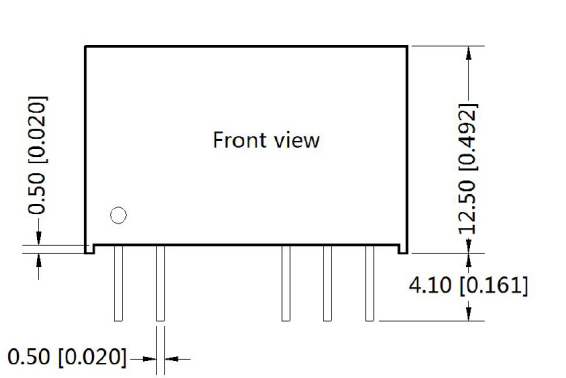

Note: Grid 2.54\*2.54mm

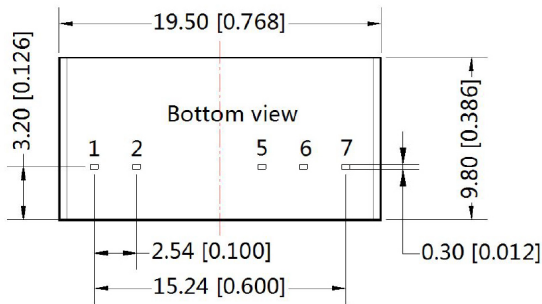

Pin-Out	
Pin	Function
1	Vin
2	GND
5*	-Vo
6	0V
7	+Vo

**Note:**  
Unit: mm [inch]  
Pin diameter tolerances: ±0.10mm [±0.004inch]  
General tolerances: ±0.5mm [±0.020inch]

**Note:**

1. The lead connecting the power supply module and IGBT driver should be as short as possible during use;
2. The output filtering capacitor should be as close as possible to the power supply module and IGBT driver;
3. The peak of the IGBT driver gate drive current is high, so low internal resistance electrolytic capacitor is recommended to be used for the power supply module output filter capacitor;
4. The average output power of the driver must be lower than that of the power supply module;
5. Consider fixing with glue near the module if being used in vibration occasion;
6. The max. capacitive load should be tested within the input voltage range and under full load conditions;
7. Unless otherwise noted, all specifications are measured at Ta= 25°C, humidity <75%, nominal input voltage and rated output load.
8. In this datasheet, all test methods are based on our corporate standards.
9. All characteristics are for listed models, and non-standard models may perform differently. Please contact our technical support for more detail.
10. Please contact our technical support for any specific requirement.
11. Specifications of this product are subject to changes without prior notice.